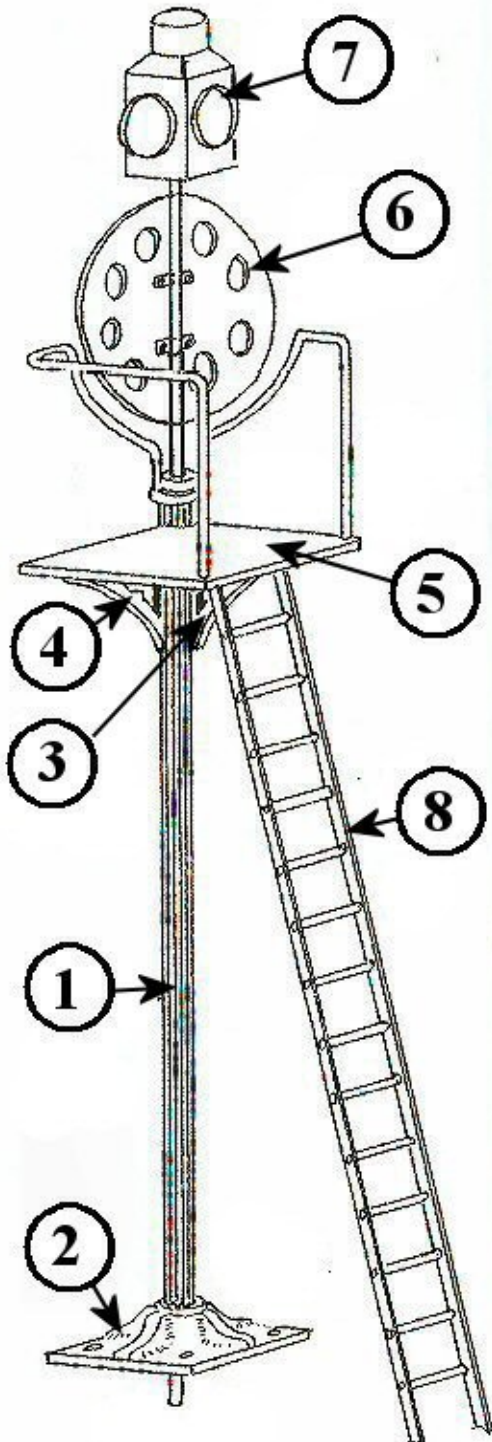




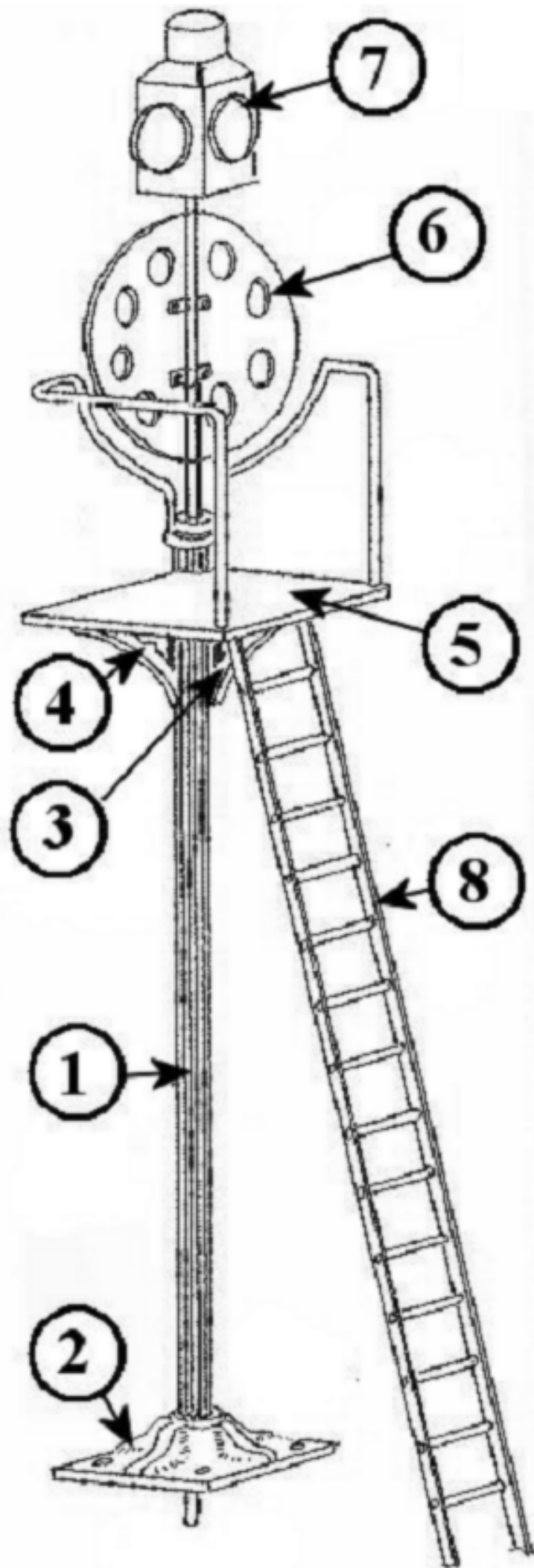
**LA2  
Disc Signal Kit**



**Brown Marshalls & Co. disc signal as  
supplied to the Ffestiniog Railway in  
1864.**

**Requires assembling and painting.**

**Roundhouse Engineering Co. Ltd.  
Churchill Business Park  
Churchill Road, Wheatley,  
Doncaster. DN1 2TF.  
Phone 01302 328035 Fax 01302 761312  
[www.roundhouse-eng.com](http://www.roundhouse-eng.com)**



## Instructions for LA2 Disc Signal Kit

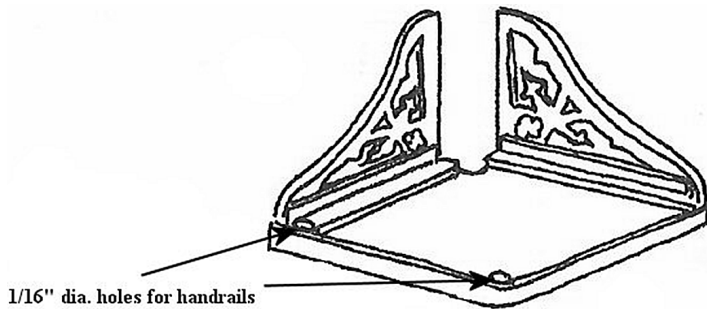
Before starting construction, read through these instructions carefully and have a dry run with the parts to check that all is well. The metal castings should be treated with respect as rough handling could cause damage. If any castings are bent, they can be straightened carefully by hand, but do not use excessive force. Any item found to be faulty should be returned to the manufacturer for replacement.

This kit consists of  
8 white metal castings.  
1 length of 3/32" diameter brass rod (fitted in column).  
1 length of 1/16" diameter brass rod.

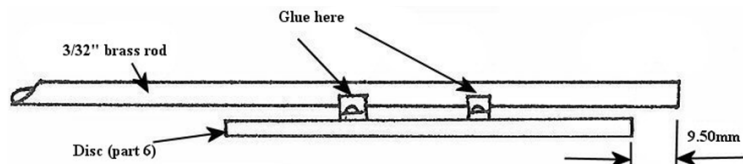
Carefully clean all parts, removing mould lines and flash with a sharp craft knife and small file.  
Remove the 3/32" brass rod from the centre of the column

Using 'Araldite' or similar epoxy adhesive, glue base (part 2) onto the bottom of the main column. Note that the top of the main column has a thicker, stepped flange with two small holes in the top for the handrails. Ensure that the two small handrail holes are in line with two of the webs on the base.

Glue the two platform support brackets (parts 3 & 4) to the underside (deepest flange) of the platform (part 5) as in diagram 2 after first drilling out the two 1/16" holes for the handrails.

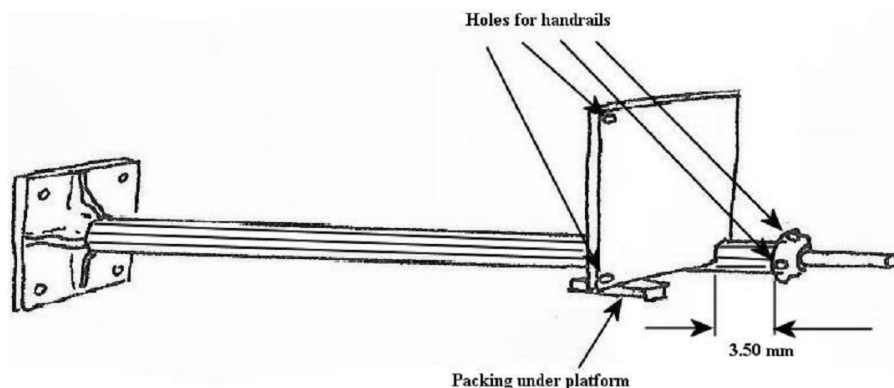


**Diagram 2—platform placed upside down and support brackets glued on.**



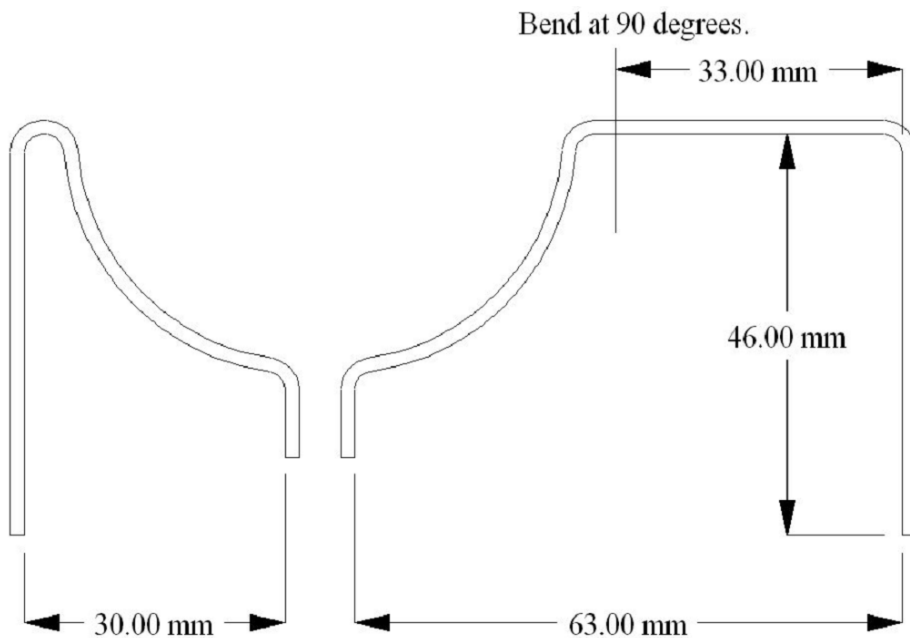
**Diagram 3—gluing the disk to the pivot rod.**

Lay the disc (part 6) on a flat surface and glue the 3/32" diameter brass rod to the two brackets on the rear face as shown in diagram 3.

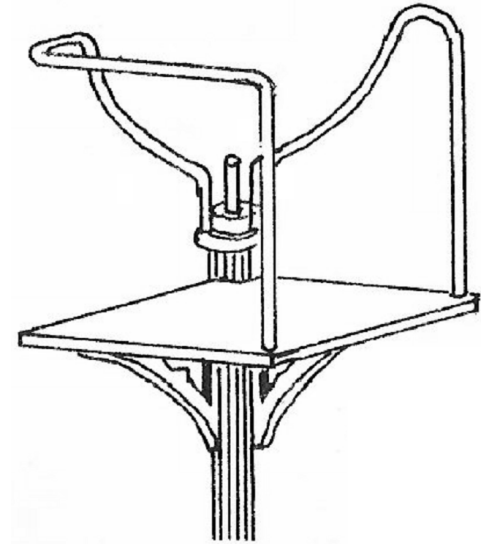


**Diagram 4—positioning platform.**

Glue the platform assembly onto the top of the column, approximately 3.50mm below the top flange. Position the platform and column so that the handrail holes line up as shown in diagram 4. Place a piece of packing under the outside edge of the platform to hold it square to the column.



**Diagram 5—handrail template.**



**Diagram 6—Handrail arrangement.**

Using 1/16" diameter brass rod, bend up the two handrails as shown in the template and glue into the holes in the top of the column and the platform as shown in diagram 6.

The complete column assembly can now be fixed to a suitable base (3" x 6" x 1/2" ply or similar) and painted. Photographic evidence suggests that the actual signals varied in paint detail but in general, white was used for the column and cast iron platform brackets, whilst the base, platform and handrails were black.

Clean out the 3/32" diameter hole in the base of the lamp (part 7) and glue it on top of the brass rod above the disc. Paint the lamp body black with the two side lenses white and the front and rear lenses red. Also, paint the disc red but leave the brass rod unpainted below the lower of the two attachment points for the disc. The rod will slide down through the hollow column and is a close fit so any paint allowed to get on it will prevent it from fitting.

The ladder can now be glued in place between the platform and the wooden base, trim ends to suit.

Lubricate the brass rod with disc and lamp attached and slide it down the hollow column until the lower attachment point of the disc rests on top of centre tube of the column.

The disc operates by rotating through 90 degrees to show either a red disc and lamp to the train (stop) or a white lamp and the disc edge on to the train (go).

The centre rod to which the disc and lamp are attached, passes right down the main column and out of the bottom. If remote operation is required, a suitable pulley or operating arm (not included) can be fixed to the bottom of this rod.